

## 1. GENERAL DESCRIPTION

Butterfly valves constitute one of the most simple, robust and economical ways of managing flows in inlet and outlet conduits (fig.1).

Butterfly valves are used for emergency functions, and although in some exceptions, mainly with small diameter valves, they have been used to regulate flow, this operation method is not recommended due to the high levels of turbulence, vibration and possible cavitations which may occur on the valve or downstream pipes.

The main use for these valves is in pressurized conduits at hydro-power plants electric plants, inlets and outlets, and for closures in the event of emergency. In the majority of cases, butterfly valves are comprised of a steel box, which is a cylindrical pipe with the same internal diameter as the conduit on which it is installed.

The advantages are mainly a result of the bi-eccentric closure geometry, which largely eliminates joint-seat friction, and makes the water flow seal the valve. It provides a continuous seal around the complete circumference and its robust design allows opening and closure in high heads.

## 2. DESIGN CHARACTERISTICS

All ORBINOX butterfly valves are designed for the specific service conditions of each particular case.

The structural evaluation is performed using the finite elements method and CAD modelling systems.

Standards and criteria used for testing:

- DIN 19704: "Hydraulic Steel Structures. Criteria for Design and Calculation"
- DIN 19705: "Hydraulic Steel Structures. Recommendation for Design, Construction and Erection"
- AWWA C-504-80
- AWWA M49: "Butterfly valves: Torque Head Loss and Cavitation Analysis"

The closure mechanism is a circular body, with a hydrodynamic lengthway section to create minimum flow disturbance and pressure drop.

The butterfly valve is not very hydrodynamic in form when operating at partial aperture. Downstream, a separation zone is formed where vibrations, swirls and cavitation may occur, this can be clearly noticed as it produces intense sounds and pipes will vibrate.

For this reason, the butterfly valves must not be used for partial aperture in a permanent manner.

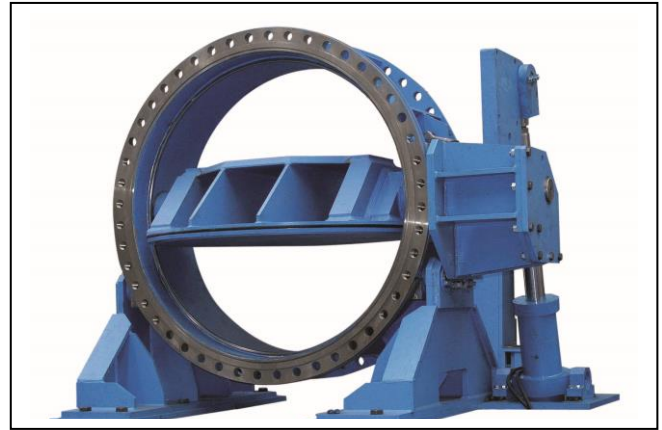

Fig.1

The butterfly seals against the seat in the body with a rubber strip that is placed around the perimeter of the disc. The rotation shafts (bi-eccentric) remain outside of the central plane of the disc (fig.2), in order to prevent interference with the rubber seals in these zones.

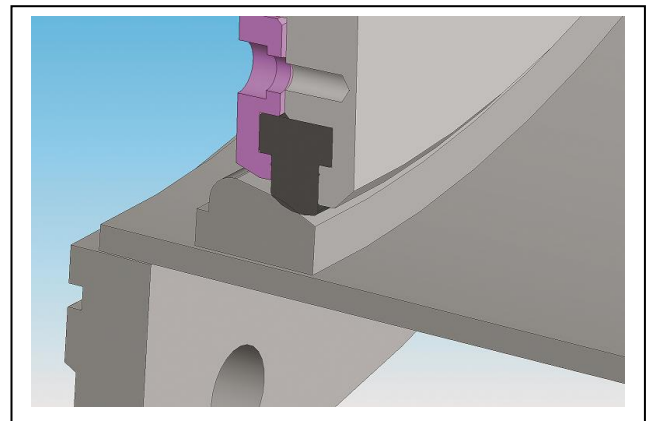

Fig.2

The rotation tendency is to close after a certain deviation of the open position, due to the distribution of pressures caused by the flow together with the bi-eccentricity of the shaft (fig.3). This means that valves of this type can be closed even without the assistance of servo-motors, or in cases of power supply failure, by manual operation, which is extremely advantageous as these valves are used as closure mechanisms in emergency situations.

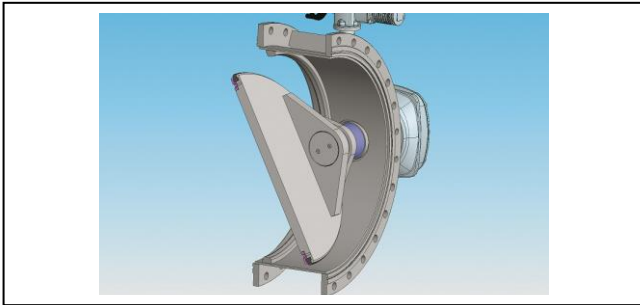

Fig.3

The actuation method which is usually used to operate these valves is an oil servo motor and counterweight system. This system uses the force of gravity of a weight outside the valve, joined to the rotation shaft of the disc by a mechanical arm. The arm is also joined to the oil servomotor which allows the valve to be opened, this in turn hydraulically or mechanically locks into the completely open position, which is the highest counterweight position. The valve closure process begins by freeing the counterweight.

The closure time can be adjusted at will by regulating the oil output of the servomotor cylinder, preventing water hammer in the pipe.

It is also possible to operate the valve with an electromechanical actuator. Manual actuation may also be carried out in cases of power failure, at least for valve closure.

When designing the operating mechanism of the valves, the following two scenarios must be considered:

### 1. Intake conduits with relatively low speeds (< 5m/s) and high pressures:

This is the case with pressurized conduits in turbine, where these valves are mainly applied as emergency devices, the resulting torque on the disc shaft will be the main force needed to overcome the friction forces on the shafts and seals; in this case, the torque from the distribution of hydrodynamic pressure on the disc will be minimal.

### 2. Bottom and general discharges in high speed conduits in which the valves must be manoeuvred with flow, under free discharge conditions:

The torque needed to overcome the forces of friction on the shafts and seals is small in comparison with the torque produced by the distribution of hydrodynamic pressures in the butterfly (dynamic torque). This torque is magnified

if the valve is larger, and if the fluid speed is higher. For this reason, on valves of a large size, a technical viability study is required. See the figure where the required correction of valve robustness for the increase in speed. (Fig. 3)

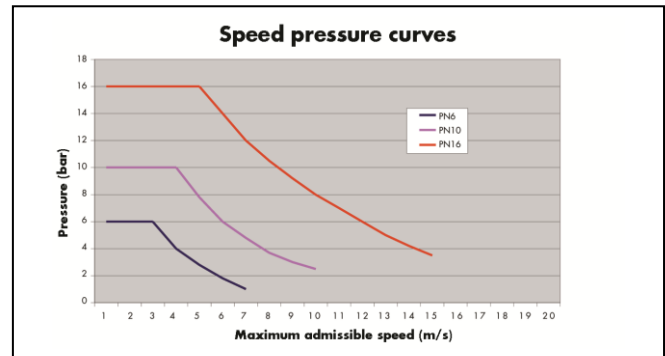

Fig. 4 Speed - pressure curves.

## 3. MANUFACTURING CHARACTERISTICS

A butterfly valve has the following elements:

- Body
- Disc
- Shaft
- Actuation cylinder
- By-pass device
- Venting system

### Body:

The body is formed by a collar with two flanges on the ends. The outer part is reinforced with ribs welded both to the collar and the flanges. The complete unit is normally manufactured in carbon steel S275JR. The closure seat is comprised of a stainless steel ring in AISI304 welded to the inside of the collar. The shaft housings are manufactured by welding highly resistant parts to the collar which then transfer radial loads to the rest of the body. After the welding process, the stabilisation process takes place along with the subsequent final machining.

### Disc:

The disc (fig.4) is formed by a main deep circular disc manufactured in carbon steel or in different qualities of stainless steel. For large and/or high pressure valves, the

is main disc reinforced with another parallel plate joined by ribs running lengthways in the direction of the water, forming a "biplane" type structure which is both very robust and hydrodynamic. The main deep disc is machined at the end in order to house the special profile of the EPDM watertight joint. This joint is held by a ring secured with a stainless steel screw.

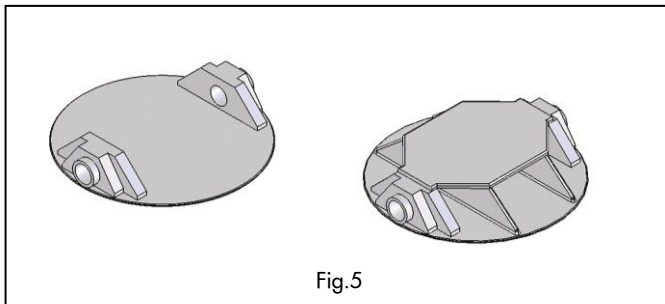

Fig.5

#### Shaft:

The shafts are solid stainless steel AISI 431 and rotate on selflubricating bronze bearings. The shafts are attached to the disc by keyways.

#### Standard actuation:

Actuation is performed by a hydraulic cylinder. In order to provide the emergency closure characteristic, the system is equipped with a counterweight. The butterfly is opened by introducing pressurised oil in one of the chambers of the hydraulic cylinder. The closure occurs by action of the counterweight, which is joined to the shaft by a lever. On releasing oil from the cylinder, the counterweight lowers closing the disc. The cylinder acts as a hydraulic absorber because when it controls the flow of released oil, the closure speed is controlled thus fast at most of its stroke to avoid water hammer and slow at the end to avoid final slam in the pipe.

The unit is dimensioned in order to be able to open and close in high head waters.

#### By-pass device:

The by-pass device is comprised of a steel pipe, and two gate valves with external spindle in stainless steel and a disassembly carriage. Thus allowing pressures upstream and downstream of the butterfly to be balanced.

#### Venting system:

The air adduction system normally consists of one or various dual function air relief valves, protected by their respective gate valves, joined to the main pipe downstream of the butterfly. Its main function is the aerate the pipe in case of a break downstream, thus preventing a collapse due to the vacuum that would otherwise be present and, in addition, to allow trapped air to be released when necessary.

## 4. ACTUATORS

This valve can be actuated manually (fig.6), electrically (fig.7) and hydraulically (fig.8), although the application usually selected is the hydraulic actuator due to the high stresses required. The hydraulic actuator may be self contained (fig. 8) or with the cylinder to the floor for increased forces (fig.1).

The hydraulic unit will normally be equipped with a double motor pump and an emergency manual pump. The hydraulic reset system used will depend on the size of the hydraulic cylinder, both accumulators and/or pressure switches (maximum and reset) may be used.

The electrical cabinet has a PLC for programming the opening, closing and emergency closing manoeuvres along with further manoeuvres specific to each case.

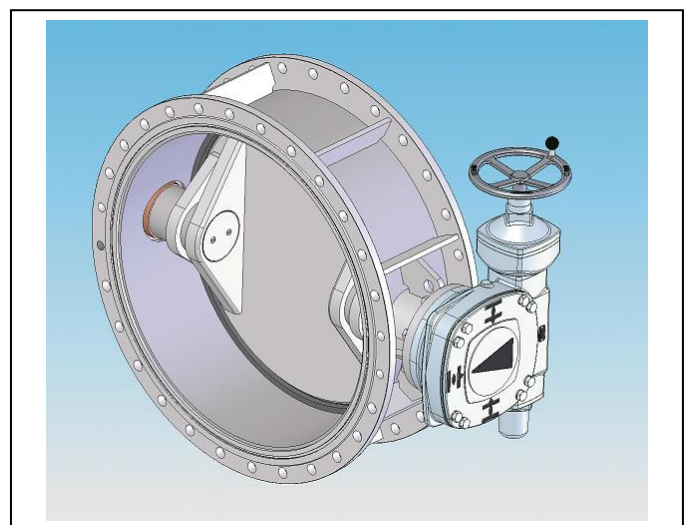

Fig. 6 Manual actuation

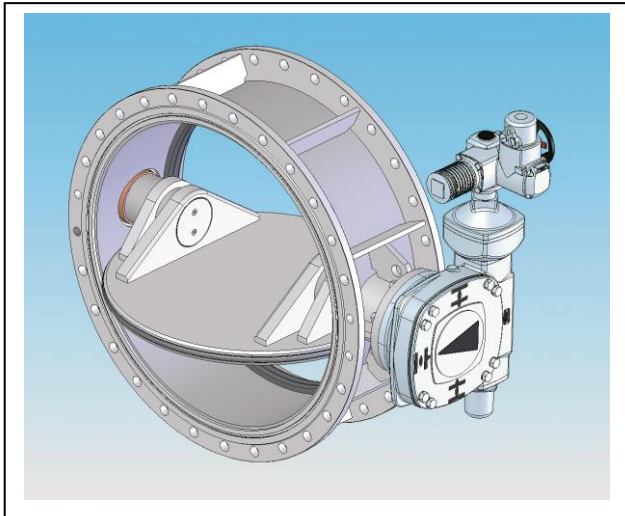

Fig. 7 Motor actuator

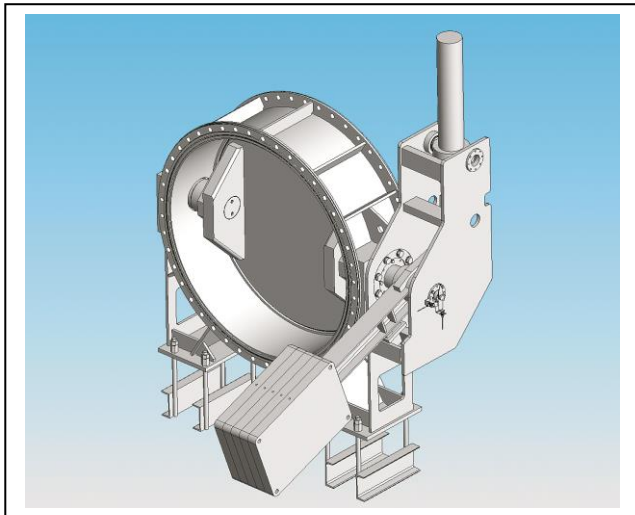

Fig. 8 Hydraulic Actuator

Steel structures in open air:

- Shot blasting SA 2 1/2
- 50 microns polyamide cured epoxy primer
- 100 microns aliphatic acrylic polyurethane finish blue RAL 5015

## 7. MATERIALS AND STANDARDS

Structural Parts:

DIN	ASTM	EN 10025
1.0044	A570 Gr40	S275JR

Stainless Steels

DIN	ANSI	EN 10088
1.4307	304L	X2CrNi1 8-9
1.4404	316L	X2CrNiMo17
1.4462	A240	

## 8. TESTS

Hydraulic Tests:

- Body at 1.5 x Design Pressure
- Valve closing at 1.1 x Design Pressure.

## 5. SERVICE AND LOAD CONDITIONS

ORBINOX butterfly valves are designed to support water loads of up to 25 bars and liquid speeds of up to 5 m/s in sizes up to Ø3500.

Consult our technicians for the combination of valve sizes and pressures with higher speeds.

## 6. ANTI-CORROSION

Steel structures permanently immersed in water:

- Shot blasting SA 2 1/2
- 50 microns polyamide cured epoxy primer
- 300 microns glassflake reinforced polyamine adduct tar free epoxy coating

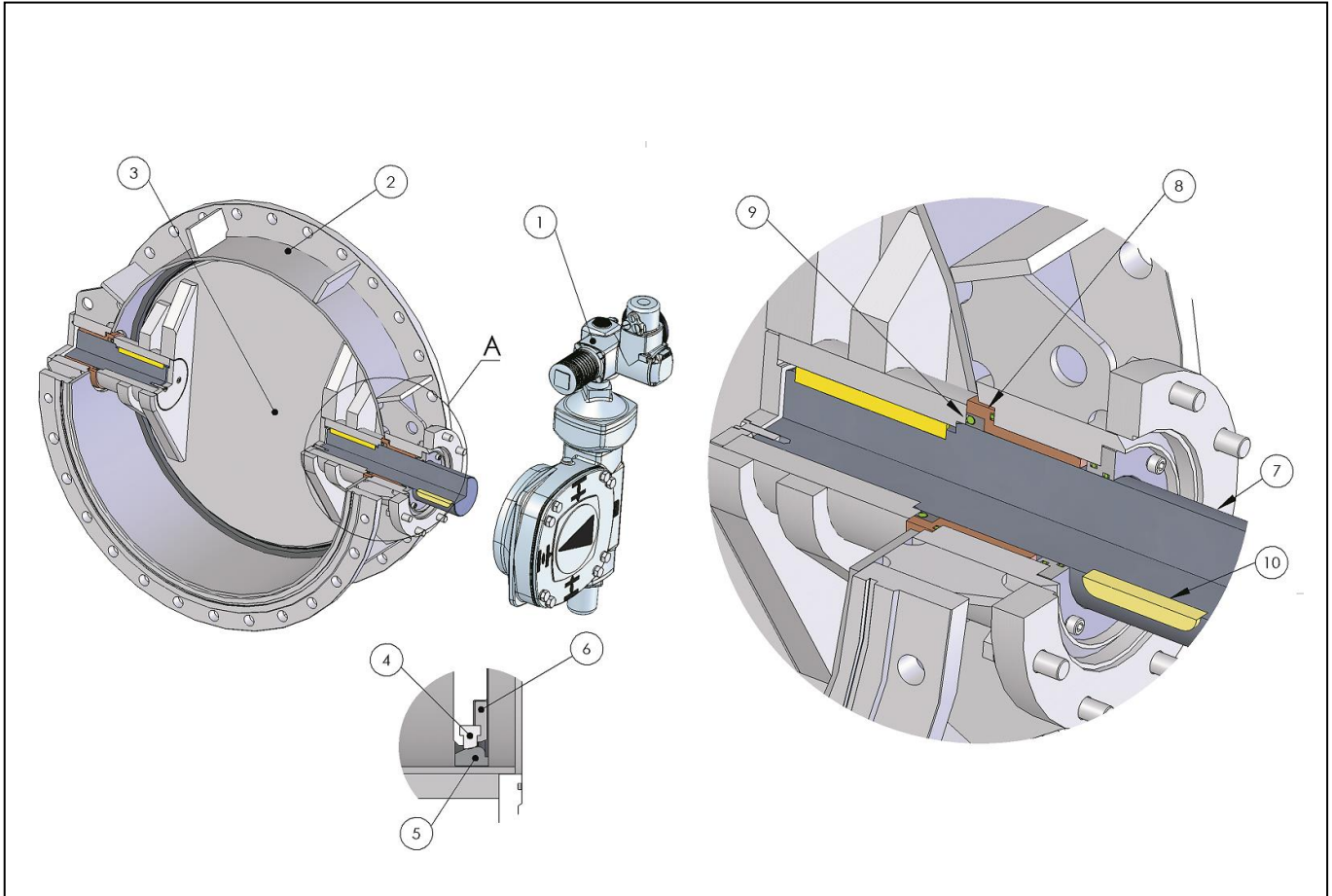

**POSSIBLE MATERIAL COMBINATIONS**

1. Actuator:	-
2. Body:	S-275-JR
3. Disc:	S275JR/AISI304L/AISI316L/DUPLEX 2205
4. Seal:	EPDM/VITON/NITRILE
5. Seat:	AISI 304/AISI316/DUPLEX 2205
6. Seal ring:	AISI 304/AISI316/DUPLEX 2205
7. Shaft:	AISI 431
8. Bearing:	Bronze, self lubricating with graphite inserts
9. Shaft seal:	EPDM/VITON/NITRILE
10. Keyway:	F114

MODEL

MB



## BUTTERFLY VALVE SPECIFICATIONS

### OPERATING CONDITIONS

Valve application: \_\_\_\_\_

Maximum operating pressure: \_\_\_\_\_ mwc

Design Pressure: \_\_\_\_\_ mwc

Maximum Flow: \_\_\_\_\_ m<sup>3</sup>/s

Emergency overspeed closure  
Yes   
No

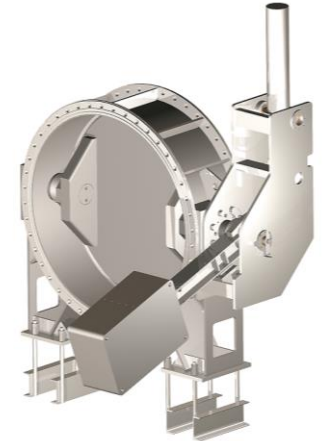

### CHARACTERISTICS

Nominal conduit diameter: \_\_\_\_\_ mm

Flange standard:  
• PN \_\_\_\_\_   
• ANSI \_\_\_\_\_   
Others \_\_\_\_\_

Actuator:  
Hydraulic + counterweight   
Hydraulic Unit   
Electrical Cabinet ( \_\_V/ \_\_Hz)   
Electric: ( \_\_V/ \_\_Hz)   
Manual   
Observations: \_\_\_\_\_

### TESTS

NDT \_\_\_\_\_

Welding approval: ASME IX   
Other: \_\_\_\_\_

### OBSERVATIONS

---

---

---

---

---